



FlexiScan

Impro FlexiScan 4-Channel Controller INSTALLATION MANUAL

SPECIFICATIONS

Working Environment	The Impro FlexiScan is designed to work in an indoor or protected outdoor environment similar to IP20. The FlexiScan is, therefore, NOT sealed against water	
Security	AES Encryption over S-Bus	
Input Voltage	12 V DC to 15 V DC	
Power Requirements	Current (mA)	Power (W)
Input Voltage 12 V DC, All 4 Relays OFF	30	0.36
Input Voltage 12 V DC, All 4 Relays ON	167	2
Relays		
Relay Output	4 Relays, each with NO, COM and NC contacts	
Relay Contact Ratings	10 A at 28 V DC 5 A at 220 V AC	
Installer Interfaces		
LED Indicators		
7-Segment Display	2 Displays, Red (externally visible)	
Push-buttons	4 Push-buttons (externally accessible)	

CONTENTS

SPECIFICATIONS	1
Contents	2
INSTALLATION INFORMATION	3
Accessories	3
General	3
Default Relay Selection.....	4
Arc Suppression.....	5
MOUNTING THE FlexiScan	6
CONNECTING THE Flexiscan	7
S-BUS CABLE CONSIDERATIONS	8
About S-Bus.....	8
There are TWO types of S-Bus Port	8
S-Bus Network Topologies	8
Connecting S-Bus Devices to an S-Bus Host	9
Supplying Power to S-Bus Devices.....	9
Cable thickness and length considerations.....	9
Worked Example.....	10
Multiple Power Supplies must be Mains Isolated.....	11
Recommended Wiring Practices.....	11
Lightning Protection and Interference Rejection	11
COMPLICATED CONCEPTS	12
USER INFORMATION.....	13
Security Code (setting, changing or clearing)	18
Accessing a Secured FlexiScan	19
TAG LOCATIONS.....	22
GUARANTEE OR WARRANTY.....	24

INSTALLATION INFORMATION

Accessories

Find the following when unpacking the Controller:

- A FlexiScan Controller: Housed in a black, translucent polycarbonate housing consisting of a Base with a 2-piece Top Cover.

CAUTION: DO NOT use the Metal-oxide Varistors (25 Vrms, 500 A, 77 V max clamping) with mains power applications.

- Four Metal-Oxide Varistors, 25 Vrms, 500 A, 77 V max clamping.
- An extra Serial Number Label.

General

Installation Considerations

The Impro FlexiScan Controller may be connected (via S-Bus) to a maximum of 8 other devices, which can be any combination of Impro (SKR) Scan Keypad Readers, Impro (QR) Quad Receivers and Impro (XSR) S-Bus Relay Boxes.

There are installation considerations for these connected devices that should be borne in mind when choosing the mounting location for the Impro FlexiScan Controller.

Please consult the Installation Manuals for the devices that you intend including in the installation before committing to a mounting position for the FlexiScan Controller.

Input S-Bus Devices (at time of print) include:

- **Impro (SKR) Scan Keypad Reader (HRK990-1-0-GB-XX)** – from which the FlexiScan can receive manually entered PIN codes, or scanned tag numbers via the SKR's integrated 125 kHz passive tag reader.
- **Impro (QR) Quad Receiver (HRR900-0-1-GB-XX, HRR901-0-1-GB-XX)** – from which the FlexiScan can receive RF tags via a 433.92 MHz radio link.

Relay distance extension

Where it would be convenient to have relays some distance from the FlexiScan, up to 150 m (164 yd.), consider using the **Impro (XSR) S-Bus Relay Box (HRK990-0-0-GB-XX)**.

S-Bus Wiring Considerations

Turn to page 8 for a clear guide on cable selection and wiring requirements.

Programming and Operating the FlexiScan

An easy FlexiScan User's Guide in table form see USER INFORMATION on page 13.

Default Relay Selection

- When using the Normal (4-Digit) PIN-code, if you enter the PIN-code on Scan Keypad Reader 1, Relay 1 is automatically selected.
- When an Impro (QR) Quad Receiver is Buttons 1 to 4 on the Impro (QT) Quad Transmitter activate Relays 1 to 4 on the FlexiScan Controller. If only Buttons 1 and 2 are pressed during the "Add RF Tags" procedure then only those Buttons will be "learned" to activate the relevant Relays. Buttons 3 and 4 will have no action. Any combination is available. See Figure 1 for Button locations.

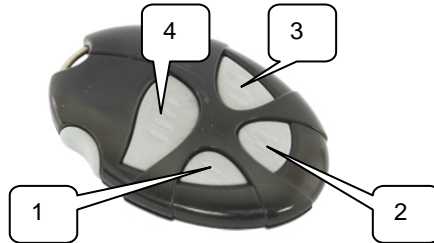

Figure 1: Button Configuration for the Impro (QT) Quad Transmitter

- The (QT) Quad Transmitter has its own passive tag, separate from the transmitted codes. Presenting the (QT) Quad Transmitter passive Tag to a Scan Keypad Reader (without pressing any button) drives that Reader's allocated Relay.

Input Source	Relay 1	Relay 2	Relay 3	Relay 4
Quad Transmitter	Button 1	Button 2	Button 3	Button 4
Passive Tag	Scan Keypad Reader 1	Scan Keypad Reader 2	Scan Keypad Reader 3	Scan Keypad Reader 4
4-Digit PIN-code	Scan Keypad Reader 1	Scan Keypad Reader 2	Scan Keypad Reader 3	Scan Keypad Reader 4
5-Digit PIN-code (Any Scan Keypad Reader)	PIN XXXX1	PIN XXXX2	PIN XXXX3	PIN XXXX4
*Request to Exit (RTE) Input	RTE Door 1	RTE Door 2	-	-

Table 1: Relay Allocation Summary

NOTE: The 5-digit PIN-codes allow any of the four relays to be activated from any of the installed Scan Keypad Readers (provided the relevant codes have been learned – see page 15).

NOTE: *Request to Exit (RTE) is only available when the Impro (XSR) S-bus Remote Relay Box is included in the installation.

Arc Suppression

Snubber devices are recommended for EMF Flyback and Arc Suppression when driving an inductive load with the Relay, see Figure 2.

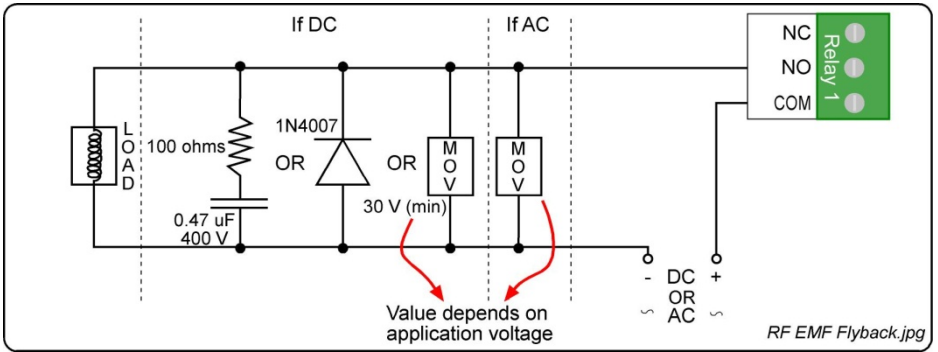

Figure 2: EMF Flyback and Arc Suppression

Blank Space

MOUNTING THE FLEXISCAN

Figure 3 shows the mechanical layout of the FlexiScan Controller with the terminal cover removed.

Secure the Cabinet to the mounting surface, using two suitable screws and wall plugs, nuts and bolts or rivets (See Figure 3 for mounting hole locations).

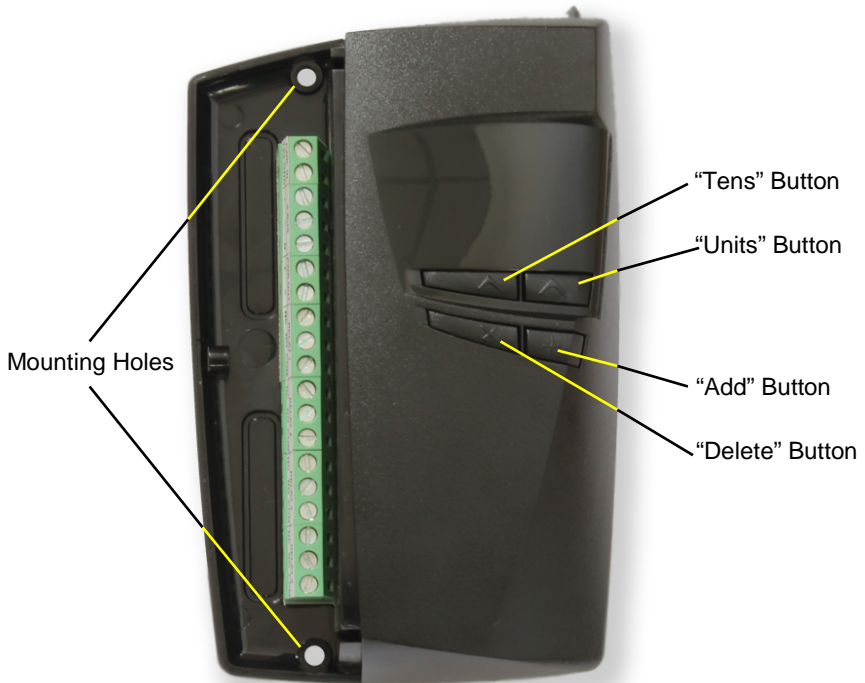

Figure 3: FlexiScan physical layout

(Electrical connections are shown on the next page)

CONNECTING THE FLEXISCAN

Connection Diagram FlexiScan.jpg

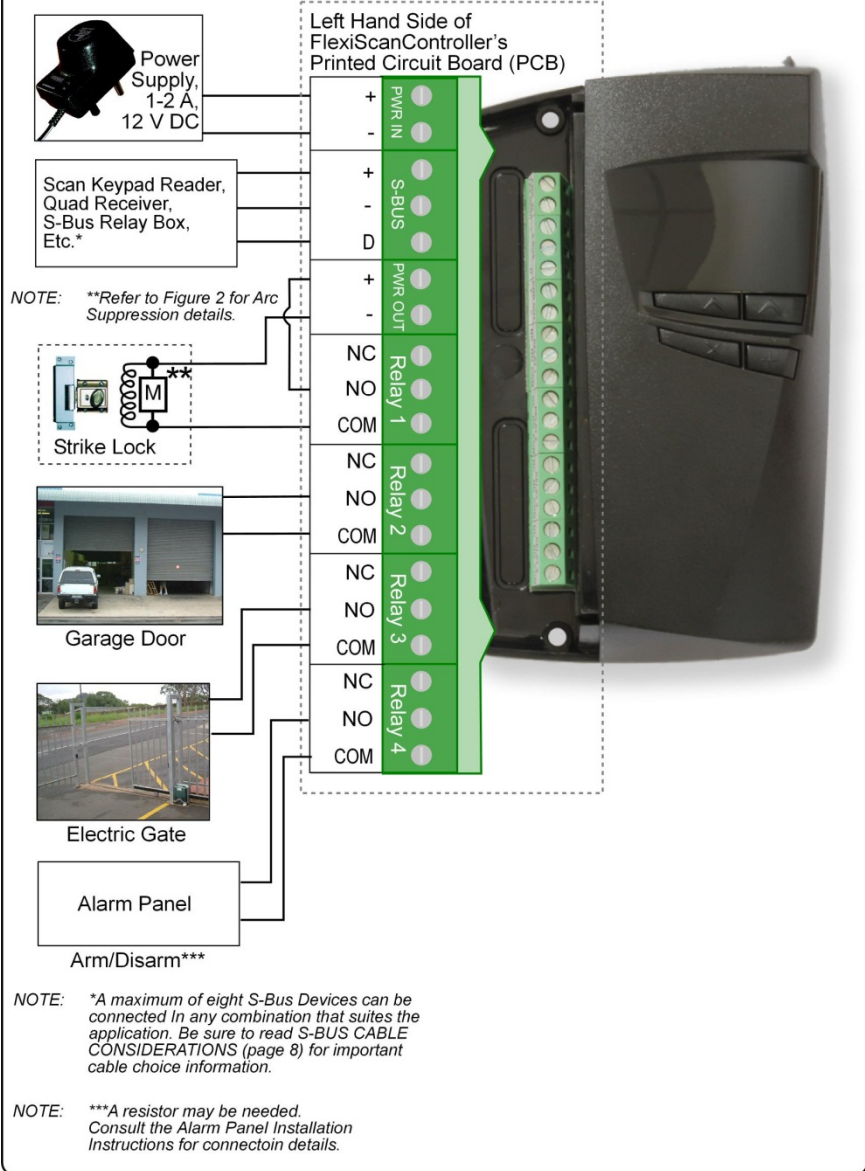

Figure 4: Typical FlexiScan Electrical Connections

S-BUS CABLE CONSIDERATIONS

NOTE: *This section of the manual must be considered for all new installations OR whenever S-Bus Devices are being added to an existing installation.*

About S-Bus

Impro S-Bus is a cost-effective, propriety, encrypted, bi-directional two-wire bus system that allows S-Bus Devices to be installed up to 150 m (490 ft.) away from their Host.

There are TWO types of S-Bus Port

Host: There can only be one **Host** per S-Bus. An S-Bus Host always features "+", "-", and "D" terminals - and optionally, an "SHD" terminal.

Device: Up to 8 S-Bus Devices may be connected in parallel on an S-Bus. An S-Bus **Device** always features "+", "-", "D" - and optionally an "ETH" terminal.

The FlexiScan Controller has an S-Bus **Host** port, and may be connected to S-Bus Devices such as the Scan Keypad Reader (SKR), the Quad Receiver (QR) and the S-Bus Remote Relay Box (XSR), etc.

S-Bus Network Topologies

S-BUS is very flexible and is not limited to a single network topology. The preferred topology would be a Star or Extended-Star network, if devices are powered from the S-BUS Host.

NOTE: *Star, Extended-Star, Daisy-chain, Bus, Hybrid, Point-to-Point, Tree and Hierarchical network topologies are all acceptable.*

Connecting S-Bus Devices to an S-Bus Host

The “D” and “-“ Terminals of the S-Bus Devices MUST all be connected to the respective Terminals on the S-Bus Host, and the following rules apply:

1. No more than a total of 8 S-Bus Devices “D” Terminals may be connected to an S-Bus Host’s “D” Terminal.
2. The cable length from the S-Bus Host to any S-Bus Device may not exceed 150 m.
3. S-Bus Devices may share the S-Bus Host’s power supply provided that the sum of these S-Bus Devices’ Peak Current Consumption does not exceed 500 mA, and suitable cable is used – see the table below.

Supplying Power to S-Bus Devices

- S-Bus Hosts are able to supply up to 500 mA to power S-Bus Devices connected to their “+” and “-” terminals.
- S-Bus Devices that have a specified peak current consumption of less than 500 mA may be powered from S-Bus Host’s “+” and “-” Terminals – OR they may be powered separately if desired.
- S-Bus Devices that have a specified peak current consumption higher than 500 mA may NOT be powered from the S-Bus Host’s “+” and “-” Terminals. Such S-Bus Devices must ALWAYS be powered from another suitable (isolated) power source. (Refer to the product’s installation manual for more information).

Cable thickness and length considerations

When powering S-Bus Devices from the S-Bus Host, this handy table makes it very easy to choose cables. The table indicates the maximum current for given lengths and gauges of cable.

Conductor Size		Cable Length			
Area (mm ²)	AWG	25m (80 ft.)	50m (165 ft.)	100m (325 ft.)	150 m (490 ft.)
1.31	16	500 mA	500 mA	500 mA	490 mA
0.82	18	500 mA	500 mA	460 mA	310 mA
0.52	20	500 mA	500 mA	290 mA	190 mA
0.33	22	500 mA	370 mA	180 mA	120 mA
0.21	24	420 mA	230 mA	110 mA	70 mA

(A worked example follows on the next page)

Worked Example

In a practical FlexiScan Controller installation, we have 4 Scan Keypad Readers (SKRs) daisy-chained on a building within 50 m of the FlexiScan Controller. We also have a Quad Receiver and an S-Bus Relay Box (XSR) at an automatic gate 100m away.

First we determine the total current to see if it is within the 500 mA capability of the FlexiScan's S-Bus Host Terminals:

Device	Current Draw	Quantity	Subtotal
SKR	50 mA	4	4 x 50 mA = 200 mA
Quad Receiver	60 mA	1	60 mA
XSR	67 mA	1	67 mA
Total:			327 mA

Since this is less than the 500 mA limit, we may power all these devices from the FlexiScan's S-Bus Host Terminals.

We use the table to determine what cable/s to use:

Conductor Size		Cable Length			
Area (mm ²)	AWG	25m (80 ft.)	50m (165 ft.)	100m (325 ft.)	150 m (490 ft.)
1.31	16	500 mA	500 mA	500 mA	490 mA
0.82	18	500 mA	500 mA	460 mA ⁽¹⁾	310 mA
0.52	20	500 mA	500 mA	290 mA	190 mA
0.33	22	500 mA	370 mA	180 mA ^(2b)	120 mA
0.21	24	420 mA	230 mA ^(2a)	110 mA	70 mA

Two suitable cabling arrangements for this installation would be:

1. 100m length of AWG18 (460mA Max) for everything
2. Two cables in a "star" arrangement:
 - a) 50m AWG24 cable (230 mA Max), which caters for the 200 mA to the SKRs
 - b) 100 m AWG20 cable (180 mA Max), which caters for the 127 mA needed for the Quad Receiver and the XSR

NOTE: *The limits indicated in the table are there to ensure that the volt drop across the cable length remains acceptable. A quick way of checking an installation is to measure the voltage across the "+" and "-" terminals on the S-Bus Device terminals – it must always be more than 11V for reliable operation.*

Multiple Power Supplies must be Mains Isolated

The use of more than one power supply in an S-Bus system is acceptable as long as the power supplies used are all ISOLATED POWER SUPPLIES – this is necessary to prevent unwanted ground loop currents via the common power and signal ground (“-”).

Recommended Wiring Practices

“Local” Power Supply connection

1. First ensure that the “+” Terminal of the S-Bus Device in question is NOT already wired to the S-Bus Host’s “+” terminal. (The “-” and “D” terminals must remain connected to the S-Bus Host.)
2. Connect the local (Mains Isolated) power supply across the “-” and “+” terminals of the S-Bus Device.

Lightning Protection and Interference Rejection

Screened cable is recommended for improved interference rejection in electrically noisy environments (near heavy current switching, or powerful radio transmitters) - and the provision of **some measure*** of (indirect) lightning protection.

NOTE: Screened cables provide a MEASURE of protection that can reduce (not eliminate) the chances of damage caused by a NEARBY lightning strike. Be warned that NOTHING can withstand a direct lightning strike. Impro Technologies does NOT claim to produce lightning proof products.*

Solder a 2.5 mm² (13 AWG) grounding wire to the **S-Bus Host** end of the screen drain wire (insulate the soldered joint so that it is not left exposed) and route this wire to the nearest electrical mains EARTH terminal – most often this may be same power socket used by the DC Power supply for the Host.





NOTE: The S-Bus Device end of the screen drain wire must NOT be connected to anything.

COMPLICATED CONCEPTS



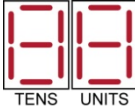

- If the Tag + PIN-code access function is required, then register a Tag at Scan Keypad Reader 1 and a 5-digit PIN-code specifying Relay 2. Relays 1 and 2 can then be wired in series. Appropriate Relay durations need to be chosen.
- If the incorrect PIN-code is entered 3 times in succession, the Keypad locks for 20 seconds. During this period the passive tag reading system remains operational.
- Presenting the (QT) Quad Transmitter's passive Tag to a Scan Keypad Reader (SKR) will activate the Relay associated with that SKR. This will only utilize 1 of your 99 Locations.

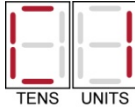
Blank Space

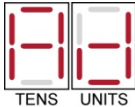
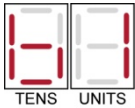

USER INFORMATION

Mode and Action	7-Segment Display LED	
	Displays	Display Duration
POWER-UP		2 seconds then enters Run Mode
RUN MODE Reading Tags		Rotates in a circular manner
Unknown Tag		2 seconds
Tag Found	Displays the Tag Memory Location (01-99)	2 seconds
PROGRAMMING MODE Adding Passive Tags <ol style="list-style-type: none"> In Run Mode press the "ADD" Push-button for less than 1 second. Press the "TENS" and "UNITS" Push-buttons until the desired Tag Location is shown. Present the Passive Tag to the Scan Keypad Reader. Press "ADD" to return to Run Mode. NOTES: <ul style="list-style-type: none"> Each new Tag Code received will display the Location at which it is being added. If the Tag already exists, it will remain in its existing location. (Nothing Changes) 		1 second
	Displays the first free Location (01-99)	2 seconds
	Displays the Passive Tag (Card) number as follows:	

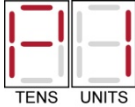
Blank Space

Mode and Action	7-Segment Display LED	
	Displays	Display Duration
Adding RF Tags 1. In Run Mode press the “ADD” Push-button for less than 1 second. 2. Press the “TENS” and “UNITS” Push-buttons until the desired Tag Location is shown. 3. Press only the Buttons on the Impro (QT) Quad Transmitter that are required to be allowed. 4. Press “ADD” to return to Run Mode. NOTES: <ul style="list-style-type: none"> Each new Tag Code received will display the Location at which it is being added. If the Tag already exists, the display will jump to the location where that tag is stored. 		1 second
	Displays the first free Location (01-99)	2 seconds
	Displays the Button Number as follows:    	
Adding Normal (4-Digit) PIN-codes 1. In Run Mode press the “ADD” Push-button for less than 1 second. 2. Press the “TENS” and “UNITS” Push-buttons until the desired Tag Location is shown. 3. Enter your 4-digit PIN-code on the Scan Keypad Reader, followed by the “#” Key on the Keypad Scan Keypad Reader. 4. Press “ADD” to return to Run Mode. NOTE: Ensure you enter the complete 4-digit code, followed by the “#” Key to gain entry.		1 second
	Displays the first free Location (01-99)	2 seconds
	Displays the PIN-code as follows: 	

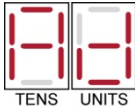
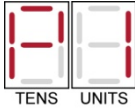
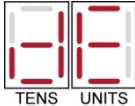
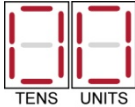
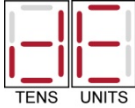
Blank Space

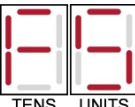
Mode and Action	7-Segment Display LED	
	Displays	Display Duration
<p>Adding Special (5-Digit) PIN-codes</p> <p>The PIN-code entered activates only the Relay specified as the 5th digit of the PIN-code.</p> <ol style="list-style-type: none"> In Run Mode press the “ADD” Push-button for less than 1 second. Press the “TENS” and “UNITS” Push-buttons until the desired Tag Location is shown. Enter your 4-digit PIN-code on the Keypad Scan Keypad Reader, followed by a 1-digit reference to the Relay you want to activate. Press the “#” Key on the Keypad Scan Keypad Reader to complete the entry. Press “ADD” to return to Run Mode. <p><i>NOTE: Ensure you enter the complete 5-digit code, followed by the “#” Key to gain entry.</i></p>		1 second
	Displays the first free Location (01-99)	2 seconds
	Displays the PIN-code as follows:	
		
<p>Deleting Tags or PIN-codes</p> <ol style="list-style-type: none"> In Run Mode press the “DELETE” Push-button. Press the “TENS” and “UNITS” Push-buttons until the desired Tag Location is shown. Press “DELETE” to delete the desired Location. Specify more Locations to be deleted, or press “DELETE” to return to Run Mode. 		1 second
		
		2 seconds
<p>Resetting to Factory Default Condition (Security Code cancelled – All Tags Erased)</p> <ol style="list-style-type: none"> Power down the FlexiScan. Power up the FlexiScan while pressing the “ADD” and “DELETE” Push-buttons. “Fd” (for “Factory Default”) is displayed. After 2 seconds all is deleted and “FS” (for “FlexiScan”) is displayed while it identifies all connected S-Bus Devices, finally returning to run mode. 		2 seconds
		Up to 15 seconds, depending on number of S-Bus Devices.

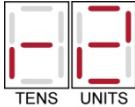
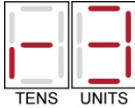
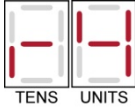
Mode and Action	7-Segment Display LED	
	Displays	Display Duration
Replacing Lost Tags 1. Delete the lost Tag from its Tag Location. (See the “Deleting Tags” section). 2. Add the new Tag to the abovementioned Tag Location. (See the relevant “Adding Tags” section).	Displays the first free Location (01-99)	2 seconds
	Displays selected Tag Memory Location	
Set Relay Durations 1. In Run Mode press the “ADD” Push-button for longer than 1 second. 2. Press the “TENS” and “UNITS” Push-buttons to specify the duration of Relay 1 in seconds (00 = Toggled Mode). <i>NOTE: The factory default setting is 01.</i>	 TENS UNITS	1 second
	Displays the Relay Drive Time in seconds (01–99 seconds)	
1. Press the “ADD” Push-button for less than 1 second. 2. Press the “TENS” and “UNITS” Push-buttons to specify the duration of Relay 2 in seconds (00 = Toggled Mode). <i>NOTE: The factory default setting is 01.</i>	 TENS UNITS	1 second
	Displays the Relay Drive Time in seconds (01–99 seconds)	
1. Press the “ADD” Push-button for less than 1 second. 2. Press the “TENS” and “UNITS” Push-buttons to specify the duration of Relay 3 in seconds (00 = Toggled Mode). <i>NOTE: The factory default setting is 01.</i>	 TENS UNITS	1 second
	Displays the Relay Drive Time in seconds (01–99 seconds)	
1. Press the “ADD” Push-button for less than 1 second. 2. Press the “TENS” and “UNITS” Push-buttons to specify the duration of Relay 4 in seconds (00 = Toggled Mode). <i>NOTE: The factory default setting is 01.</i>	 TENS UNITS	1 second
	Displays the Relay Drive Time in seconds (01–99 seconds)	
3. Press “ADD” for less than 1 second to go back to Run Mode.		

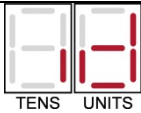
Mode and Action	7-Segment Display LED	
	Displays	Display Duration
<p>Adding / Removing S-Bus Devices</p> <p>If you have added* or removed any S-Bus devices you may refresh the S-Bus Device register without having to cycle the FlexiScan's power supply. From run mode hold the "TENS" button down for 1 second. After identifying all S-Bus Devices connected to it, the FlexiScan will return to run mode.</p>		Up to 15 seconds

***NOTE:** *If you are adding any devices be sure to read the section on **S-Bus Cable Considerations** on page 8.*



Blank Space

SECURITY CODE (SETTING, CHANGING OR CLEARING)

Should users require that the FlexiScan be secured to prevent unauthorised access to tag locations or relay settings, a 4-digit Security Code may be set. This code will then have to be entered before any Tag Locations or settings can be changed.

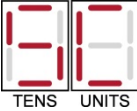
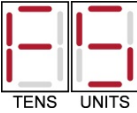

The default Security Code is 0000 ("Cleared"), which keeps the FlexiScan in the **unsecured** state, allowing free access to the Tag Locations and programming settings.

NOTE: Choose a Security Code that you are unlikely to forget, or keep it written down in a safe place, as the only way to regain access to the programming settings without the Security Code is by resetting the FlexiScan to its Factory Default Condition (Page 15), which erases all tags, PIN codes and relay settings from memory

Mode and Action	7-Segment Display LED	
	Displays	Display Duration
1. Power on the unit while holding the Delete button until "SC" is shown on the display.		
2. Use the "TENS" and "UNITS" buttons to enter the 1st and 2nd digits of the EXISTING Security Code (00 if in unsecured state).	Displays the 1st and 2nd digits of the Security Code	
3. Press "DELETE"		
4. Use the "TENS" and "UNITS" buttons to enter the 3rd and 4th digits of the EXISTING Security Code (00 if in unsecured state).	Displays the 3rd and 4th digits of the Security Code	
5. Press "DELETE"		
6. Use the "TENS" and "UNITS" buttons to set the 1st and 2nd digits of the NEW Security Code.	Displays the 1st and 2nd digits of the NEW Security Code	
7. Press "DELETE"		
8. Use the "TENS" and "UNITS" buttons to set the 3rd and 4th digits of the NEW Security Code.	Displays the 3rd and 4th digits of the NEW Security Code	
9. Press "DELETE", displays shows "US" (for "FlexiScan"), while it identifies all connected S-Bus Devices		Up to 15 seconds
10. FlexiScan enters run mode, scanning for tags.		Rotates in a circular manner

Accessing a Secured FlexiScan

NOTE: This is only necessary if you are prompted with “SC” on the display when pressing the “ADD” or “DELETE” button while in run mode.

Mode and Action	7-Segment Display LED	
	Displays	Display Duration
1. Begin with the FlexiScan in run mode.		Rotates in a circular manner
2. Press “ADD” or “DELETE” and (if the FlexiScan is locked) you will be prompted for the Security Code by the “SC” on the display.		
3. Use the “TENS” and “FLEXITS” buttons to enter the 1st and 2nd digits of the Security Code.	Displays the 1st and 2nd digits of the Security Code	
4. Press “ADD” or “DELETE” 5. Use the “TENS” and “FLEXITS” buttons to enter the 3rd and 4th digits of the Security Code.	Displays the 3rd and 4th digits of the Security Code	
6. The FlexiScan will now allow you to select any of the programming mode options listed in the tables that begin on page 13 by using the “ADD” or “DELETE” buttons for the required duration. Note that this “unlocked” state will end if there are no buttons pressed for 30 seconds (FlexiScan prompts you again for the Security Code, displaying “SC”).	Displays the programming mode that you select.	

NOTE: If you have forgotten or lost the Security Code, the only way to regain access to the programming functions is by resetting the FlexiScan to its Factory Default Condition (Page 15). This will result in the loss of all programmed information and will require re-learning of all tags and PIN codes.

User Notes

User Notes

TAG LOCATIONS

Document all Tag owners at their respective Tag Memory Locations (in the FlexiScan) using Table 2. This list provides an easy reference when you need to delete Tags from the FlexiScan.

Owner		Relay or PIN-code					Owner		Relay or PIN-code				
		1	2	3	4	5/R			1	2	3	4	5/R
01							27						
02							28						
03							29						
04							30						
05							31						
06							32						
07							33						
08							34						
09							35						
10							36						
11							37						
12							38						
13							39						
14							40						
15							41						
16							42						
17							43						
18							44						
19							45						
20							46						
21							47						
22							48						
23							49						
24							50						
25							51						
26							52						

Owner		Relay or PIN-code					Owner		Relay or PIN-code				
		1	2	3	4	5/R			1	2	3	4	5/R
53							77						
54							78						
55							79						
56							80						
57							81						
58							82						
59							83						
60							84						
61							85						
62							86						
63							87						
64							88						
65							89						
66							90						
67							91						
68							92						
69							93						
70							94						
71							95						
72							96						
73							97						
74							98						
75							99						
76													

Table 2: Tag Location Table

Blank Space

GUARANTEE OR WARRANTY

CAUTION: We reserve the right to nullify the products guarantee or warranty where you have not properly installed the Metal-oxide Varistors.

This product conforms to our Guarantee or Warranty details placed on our Web Site to read further please go to www.impro.net.



This manual is applicable to the FlexiScan
4-Channel Controller, HCM991-0-0-GB-01
(The last two digits of the stock code indicate the issue status of the product)

HCM301-0-0-GB-01	Issue 02	June 2013	FlexiScan\English Manuals\LATEST ISSUE\FlexiScan-insm-en-02.docx
------------------	----------	--------------	---