

# Maintenance operations

## Cube C-01 turnstile

---



[www.oxgard.com](http://www.oxgard.com)

[info@oxgard.com](mailto:info@oxgard.com)

Tel. +7(812) 366-15-94



## CONTENTS

1. General instructions.....	4
2. Conditions for performance of technical maintenance .....	5
3. Partial disassembly of the turnstile .....	5
4. Checking turnstile assemblies .....	11
5. Lubricating sliding parts of turnstile mechanisms .....	11
6. Assembly and functionality test of the turnstile .....	14

## **1. General instructions**

1.1. During operation of the turnstile in order to maintain efficiency and to ensure calculated lifetime the maintenance operation of the turnstile shall be carried out periodically, including the warranty period (hereinafter MO).

1.2. MO shall be performed once in 6 months. Should there be any failure MO should be performed immediately after repair works.

1.3. During MO it is recommended to carry out the work by two qualified mechanical and electrical engineers, acquainted with the manual.

1.4. MO includes the following scope of work: partial disassemble of the turnstile, cleaning of load-bearing frame, checking of parts and units fixation, lubrication of subject to wear parts of actuating device, checking of belt tension, setting the dismantled parts and a general inspection of the turnstile.

## 2. Conditions for performance of technical maintenance

**ATTENTION!** It is strongly forbidden to perform works with connected power of the turnstile. A failure to observe safety requirements, indicated in this Section, may cause damage to life and health of people, complete or partial loss of operating capability of the product and (or) auxiliary equipment.

**ATTENTION!** It is strongly forbidden to unfasten a cross-board, located under the indication panel. Otherwise the manufacturer will terminate the validity of warranty for the product.

**ATTENTION!** It is not recommended to adjust stroke limitation units for solenoids, neither to adjust tension of springs. These units have been adjusted at the factory. Disturbance of these adjustments may cause malfunctions for the whole electromechanical system.

## 3. Partial disassembly of the turnstile

General View of the turnstile is shown on Fig.1

Switch off the power supply unit of the turnstile and disconnect it from the mains.

To get an access to all required units of the turnstile it is necessary to disassemble the turnstile partially. This scope of works includes removal of the protective backshell. In order to get that done unscrew two screws (1) and four screws (2), smoothly move the backshell up at a small distance so that not to break the cable, coming to the indication board (Fig. 2). Disconnect the cable from the indication board.

Move the backshell up to the end and release an access to the swivel mechanism. The view after removal of the backshell is shown on Fig 3.

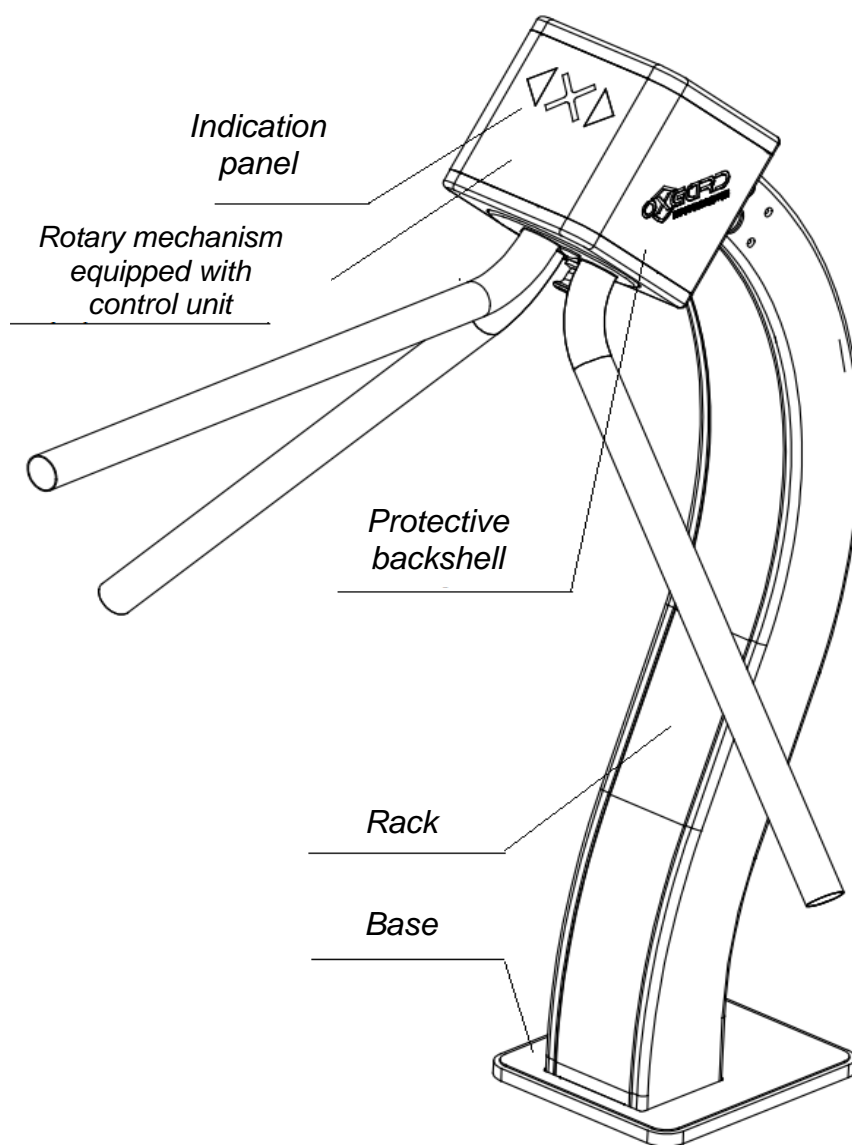

*Fig.1*

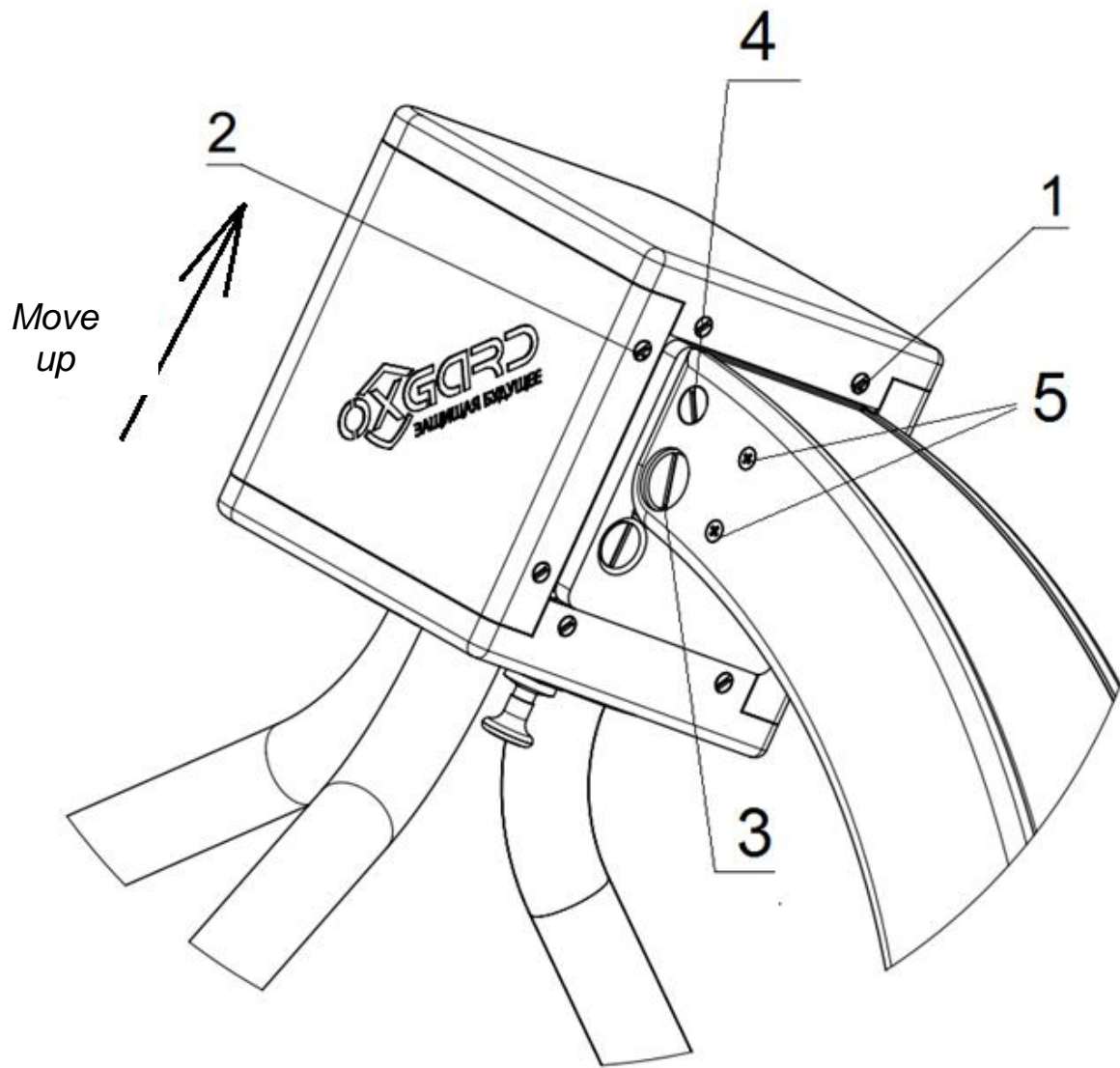

*Fig.2*

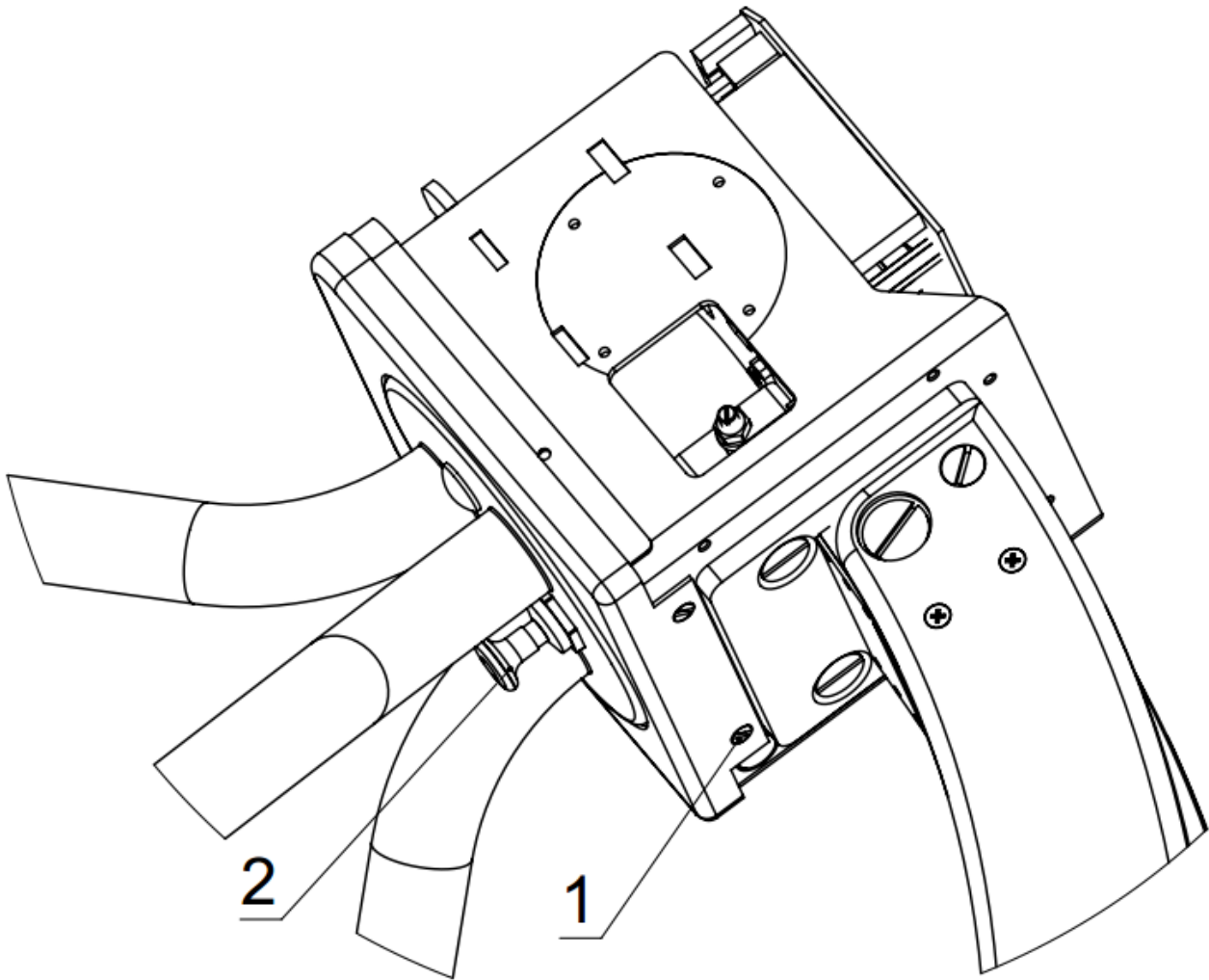

*Fig.3*

Fold arms for ease of further work, to achieve this retract fixation lock 2 of the crossbars (Fig.3) and while holding one crossbar in a fixed position rotate the other crossbar by the other hand clockwise so that all the crossbars would align (Fig 4), put folded arms down (Fig 5) .



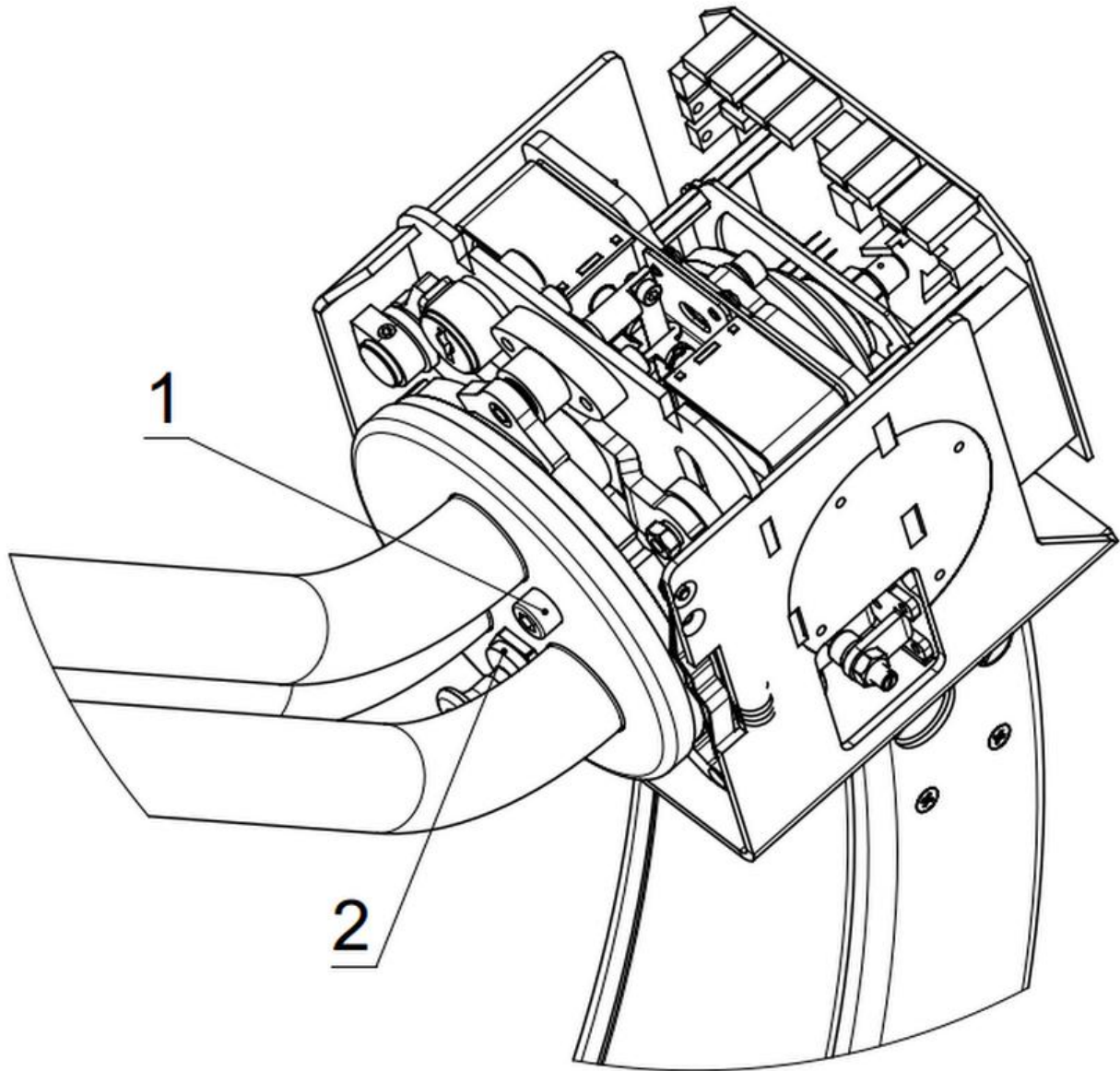

*Fig.4*

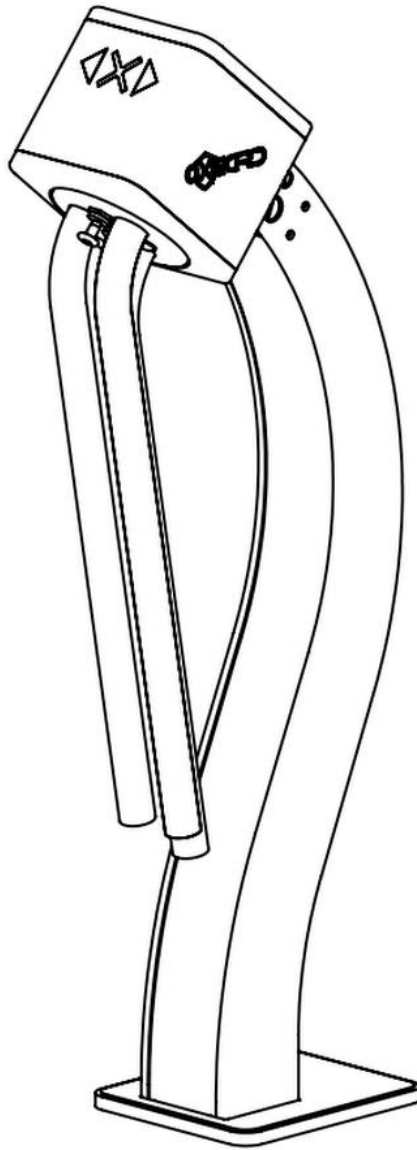

*Fig.5*

#### **4. Checking turnstile units**

- 4.1. Clean turnstile parts from contaminants.
- 4.2. Check if all the cables are properly connected.
- 4.3. Check and tighten if necessary thread connections that fasten turnstile units.

#### **5. Lubricating moving parts of turnstile mechanisms**

To get an access to the assemblies, for lubrication of the moving parts of turnstile mechanisms it is required to:

1. Remove lower decorative board having undone two screws 1 (Fig.6)
2. Remove arms unit - to get this:
  - 2.1. Unscrew fixation lock 2 with box spanner D22
  - 2.2. Loose a screw M8, which is in the hole where the fixation lock was secured with hexagonal key S6.
  - 2.3. Loose two screws 1 (Fig.4) M8 with hexagonal key S6
  - 2.4. Remove arms unit.

Lubricate the details of the turnstile mechanism (Fig.7) indicated with numbers 1, 2, 3 and 4.

Lubricating is performed by engine oil of viscosity grade 5W-20 at a rate of 2 - 3 drops in each slide assembly.

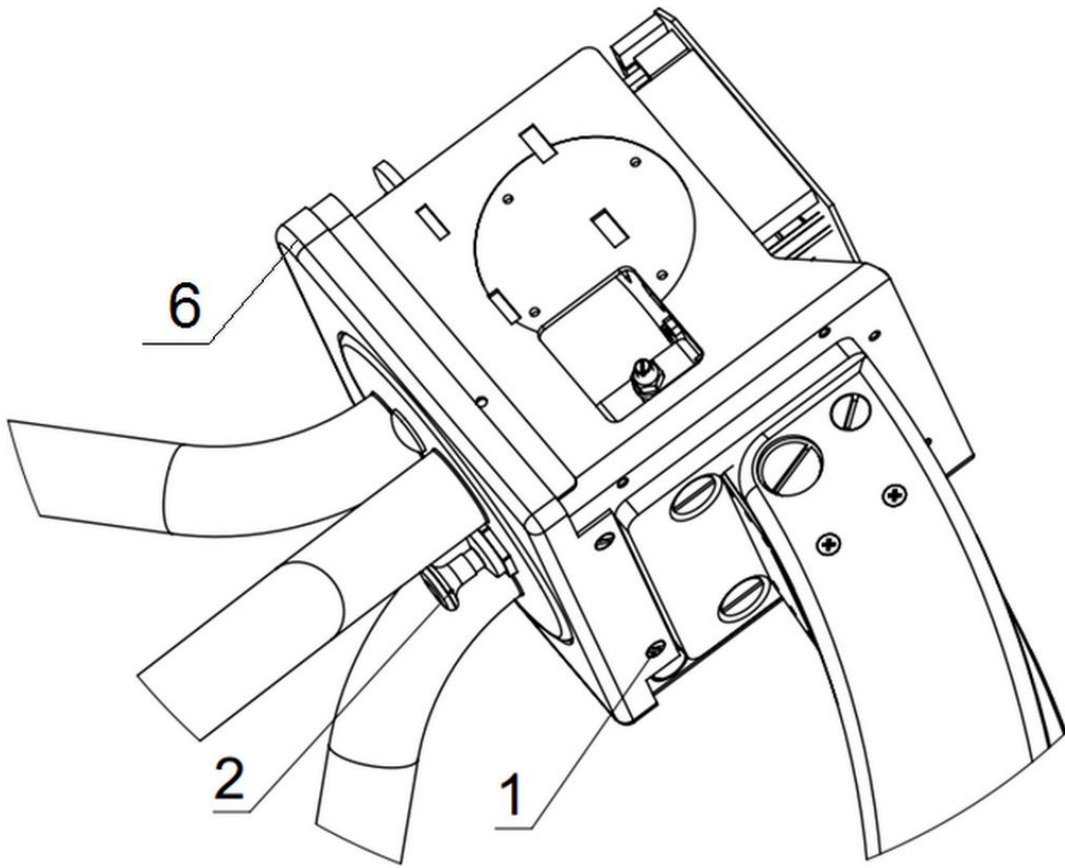

*Fig.6*

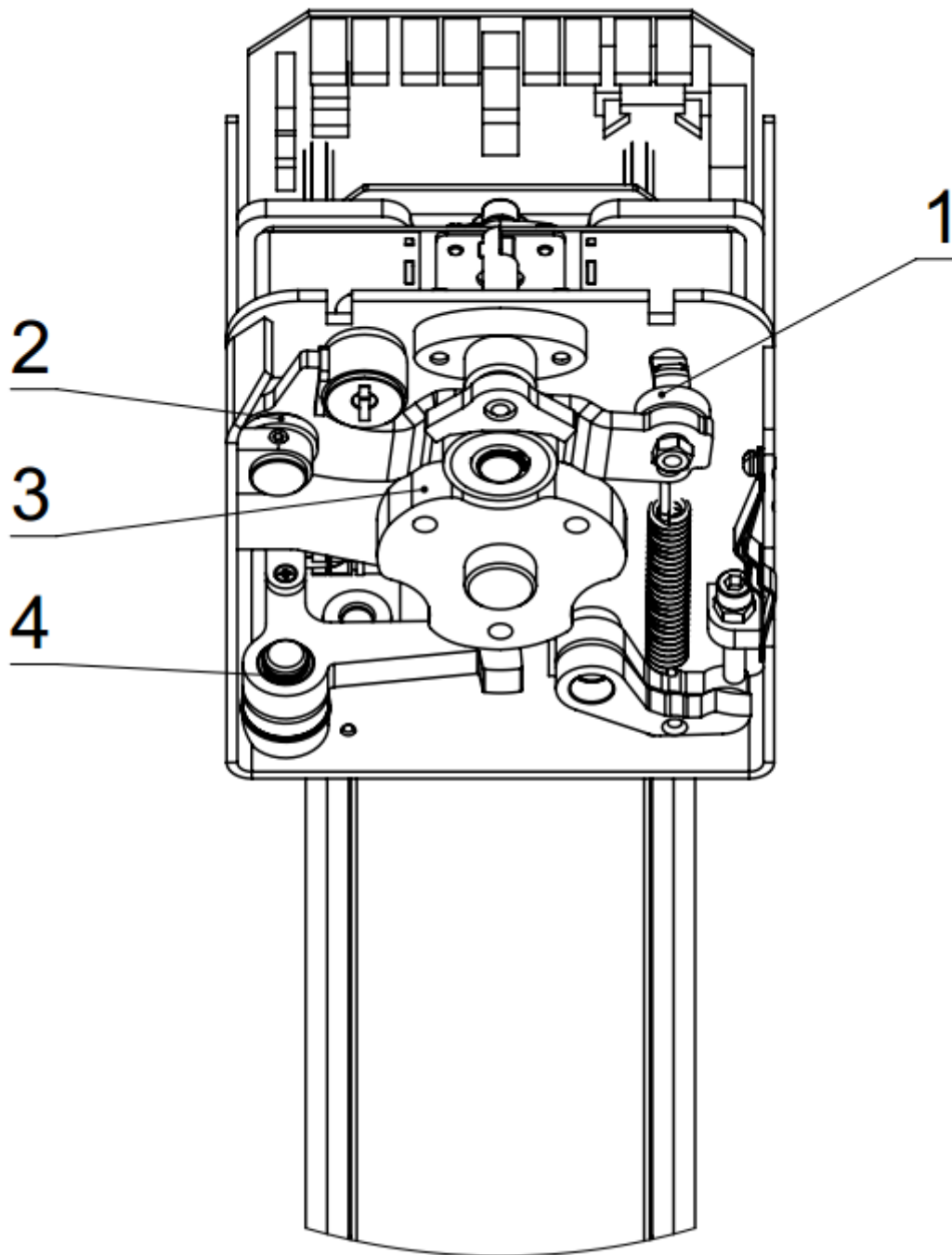

*Fig.7*

## **6. Assembly and functionality test of the turnstile**

6.1. In case some faults of its units are detected in the process of turnstile TM it is recommended to consult the customer care. List of addresses of the official dealers and service centers is provided in the Operator's manual and is available on the web-site: [www.oxgard.com](http://www.oxgard.com)

6.2. In case of repair of damaged painted surfaces one should use powder paint, identical to the damaged (RAL9005), guiding the instructions for its use.

6.3. Fulfill an assembly of the turnstile in the reverse order.

6.4. Connect the power of the turnstile and carry out functionality test, having done several test runs.

6.5. If there is neither abnormal noise nor any violations of the operation modes the turnstile is ready for operation.



ООО “Vozrozhdenie”  
66, Sofiyskaya str.,  
192289, Saint-Petersburg  
tel./fax +7 (812) 336 15 94  
[www.oxgard.com](http://www.oxgard.com)  
[info@oxgard.com](mailto:info@oxgard.com)